

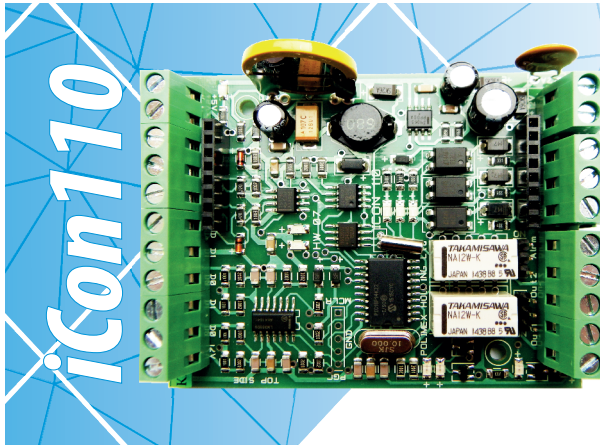

<http://goo.gl/ffX953>

# USER MANUAL

## Intelligent controller for access control and Time & attendance



- Standalone mode with Master card;
- Ability for **USB / LAN / WIFI / GPRS communication** through additional module;
- Ability for bus bar **RS485** communication (**up to 253 devices**);
- Automatically **switch over mode of communication** – controller/converter RS485 to USB or LAN simultaneously;
- Ability for measuring **work time** with Andromeda Pro and Polimex Cloud (<http://my.polimex.online>);
- Management of **two doors** unilaterally or **one door two-sidedly**;
- Ability for management of paid services with Andromeda Pro and Polimex Cloud – parking lot, fitness, spa, etc.;
- Ability for **emergency opening** by an external system;
- Automatic actuation of the exits by preliminary set time-graph – up to 480 pcs;
- Supports time-graphs for limitation of the access – up to 480 pcs;
- Supports user requested settings of states (conditions), by default, of the entrances and the exits;
- Non-volatile memory and watch;
- Ability of managing turnstile with the antipassback function;
- **Opened WEB SDK** record for integration;
- Automatic mode of work: autonomous or mains (connection with software);
- Incorporated **Duress Mode** function (forced door opening with silent alarm);
- Digital sensor input for **temperature and humidity**.

Capacity of consumers	1536
Event memory	3056
Readers	2 interface of the readers: 26 or 34 bit WIEGAND (automatically set) and 4-8 bit figures for a PIN
Readers' mode	card, card and PIN, card or PIN, card and operational code
Inputs	2 galvanically partitioned, 1 emergency input
Outputs	2 Relay outputs 30V/2A 1 O.C. 30V/0.2A alarm output
Communication	RS 485 (LAN, USB with module)
Supply voltage	12 VDC
Operating current (mA)	60
Light indicating device	Yes
Operating temperature	-10°C - +50°C
Operating humidity (RH)	10%- 90% RH ( non-condensing)
Dimensions (mm)	80*63*22

# Wiring Diagram

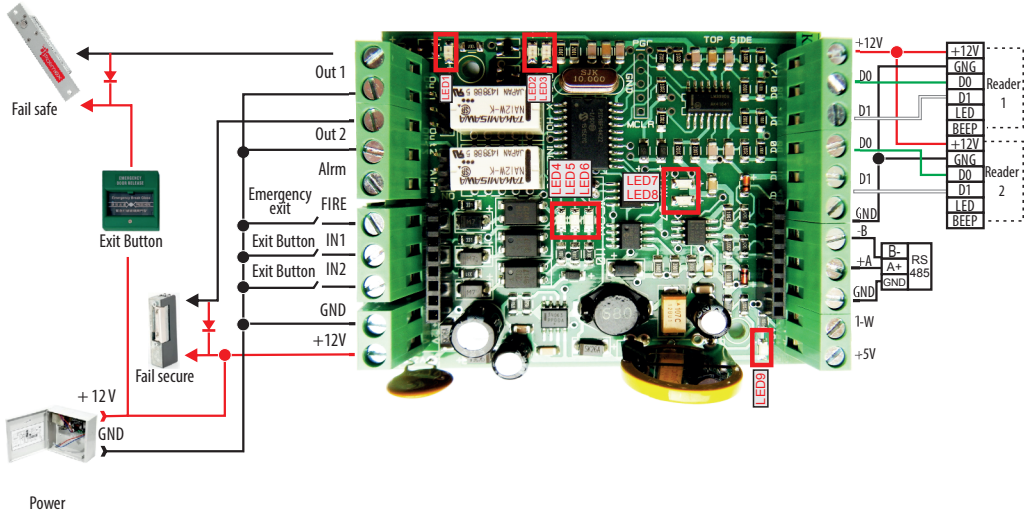

Wiring Diagram LED and BEEP

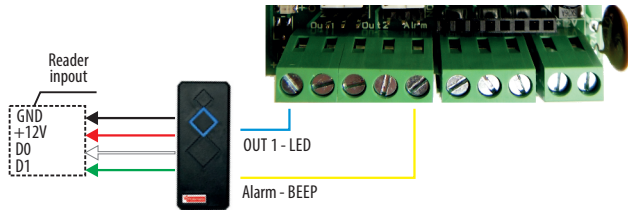

Table with iCON110 functionality

Controller Inputs	Controller Mode 1 door	Controller Mode 2 doors
IN1	Exit Button Door 1	Exit Button Door 1
IN2	not use	Exit Button Door 2
Fire	Fire	Fire
R1	Door 1 In Reader	Door 1 In Reader
R2	Door 1 Out Reader	Door 2 In Reader
<b>Изходи</b>		
OUT1	Door 1 Out	Door 1 Out
OUT2	General Purpose Out	Door 2 Out
OUT3	Alarm O.C. Out	Alarm O.C. Out

Light-emitting diodes for work indication

Led №	Description	Status	
Led 1	Alarm	On. <span style="color:red">■</span>	Off. <span style="color:red">□</span>
Led 2	Out 2	On. <span style="color:red">■</span>	Off. <span style="color:red">□</span>
Led 3	Out 1	On. <span style="color:red">■</span>	Off. <span style="color:red">□</span>
Led 4	Fire	On. <span style="color:green">■</span>	X
Led 5	In 1	On. <span style="color:green">■</span>	Off. <span style="color:green">□</span>
Led 6	In 2	On. <span style="color:green">■</span>	Off. <span style="color:green">□</span>
Led 7	Communication Rx	Blink <span style="color:green">■</span>	X
Led 8	Communication Tx	Blink <span style="color:red">■</span>	X
Led 9	Tx Power U	On. <span style="color:blue">■</span>	X

# Recommendatory types of cables and permissible lengths

Table with lengths when supply is 13.7VDC

The recommendatory type of cable for establishing connection between the controller and the peripheral units of the system is multicore 2x0.5+8x0.22. (2x0.5 is used for management of the locking mechanism, and the rest 8x0.22 – for supplying the readers, data from the readers, management of the buzzer and the light-emitting diode indication of the readers, exit button, magnetic-controllable stud, bell, etc. If the cores are not enough in quantity, full virtual mass could be used (for example: the black 0.5mm).)

№	Equipment:	Cabelas-mm	max. m
1	Reader	0.22	to 100
2	Door contact	0.22	to 100
3	Exit Button	0.22	to100
4	LED and Buzzer	0.22	to 100
5	Electromagnetic Lock (550mA) Polimex	0.5	to 30
6	Electric Strike Polimex	0.5	to 70
7	Electric Bolt Polimex	0.5	to 40
8	RS-485	FTP min.5 cat.	to 1200
9	LAN	FTP min. 5 cat.	to 100
10	USB	Standart Cabel	2-3 м
11	Emergency Exit Button	0.5	At the door

## Wiring Diagram

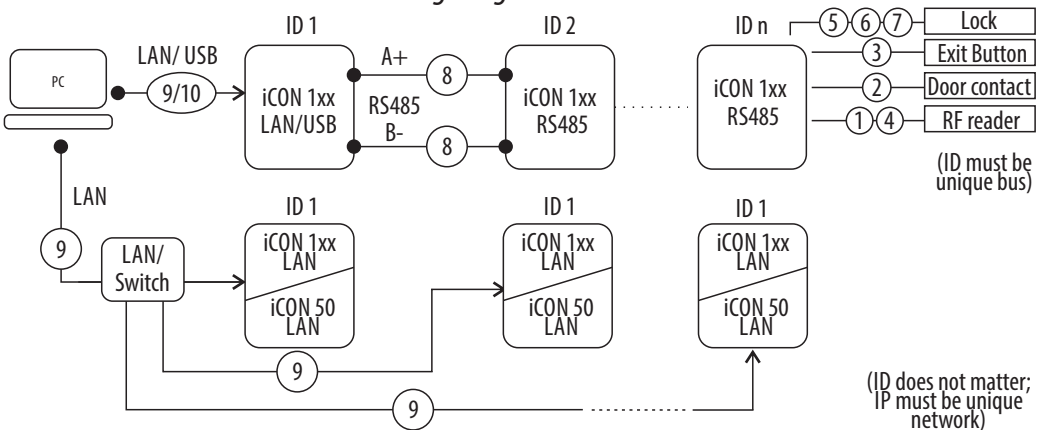

## Connection in a bus bar through RS485 communication interface

A connection in a bus bar RS485 allows the construction of bigger systems. The transmission medium is a twisted pair cable with a maximum length of 1200m. We recommend the use of h-type cable (the screen at the one of the ends of the cable needs to be grounded). If there is not a suitable grounding point, the screen should be connected to the virtual mass of the converter or the controller, acting as a converter. With the purpose of lowering the noise level, termination of the line is recommended (especially if it is longer). The amount of the terminating resistance depends on the length of the line, as follows:

- For bus bars up to 50m, do use 1kΩ resistor
- For bus bars up to 150m, do use 620Ω resistor
- For bus bars over 150 m, do use 300Ω resistor

The personal computers do not support RS485 interface, which forces the use of a signal converter. For successfully doing this, the use of LAN or USB module is advisable. These modules could be connected to every single controller of the iCON1xx series without any kind of hardware or firmware corrections. In order not to interrupt the topology of the controller web, one of the controllers in the bus bar could act as a converter. The use of an external converter is also possible.

Each controller in the bus bar has its own address with a value of 0 to 254. ADDRESS DUPLICATION IN THE BUS BAR IS NOT PERMITTED. The address of each controller is written on its identification mark.



# FAQ

**Q: I do not know the controller's address. How can I find it?**

A: The address of each controller is written on its identification mark. In case the address is removed or changed (without this being written on the identification mark), it could be found by the PolimexAutoDetect software or by the incorporated into the free AndromedaTool software function for searching and finding controllers. In case you do use LAN communication – in the WEB interface of the LAN module you should open the SDK Device Manager and click on the Start button. A complete list of all the controllers in the bus bar will appear.

**Q: What kind of potential do the controllers' outputs apply?**

A: When the controllers' outputs are actuated, virtual mass (GND) is applied.

**Q: How can I restore the normal working state of the controller after it had entered Fire mode?**

A: Do assure that the signal transmission from the Fire Alarm Station to the controller is suspended. The controller will then automatically revert to its normal working state.

**Q: Which is the input and which is the output reader?**

A: Usually reader 1 is incoming and reader 2 is outgoing (when one door two-sidedly mode is active); this kind of partition is conventional.

**Q: Is an external relay needed at the output?**

A: The output is made to commutate current up to 0.3A in an impulse mode (up to a few seconds). If it is necessary for the actuating mechanism to be active longer, we advise using an additional relay. There is not an unambiguous answer. Everything depends on the concrete case.

**Q: On which locking mechanisms a diode should be put?**

A: Protective diodes are put on every single locking mechanism, independently of the type. However, the diode must be put immediately next to the locking mechanism.

**Q: How do I install the controller in the container?**

A: In the set you do receive 2 pcs of remote-control bushes.

**Q: How do I put the LAN module?**

A: The RJ45 adjuster should be orientated towards the supplying input of the controller, pointed towards the external part of the plate.

**Q: How do I put the USB module?**

A: The USB module is inserted into the adjuster (which is immediately next to the pile), pointed towards the internal part of the plate.

**Q: How the indication of the reader is to be managed?**

A: The indication of the reader is managed by applying "0" (virtual mass) to the corresponding conductor – for managing the LED or the buzzer.

**Q: What is the distance allowed between the controller and the reader?**

A: Theoretically the standard defines maximum 100m of length between the two components. This depends on the conductors used. Do check the table where the recommendatory types of cables and permissible lengths are written (p.3).

**Q: What is the permissible length to the locking mechanism?**

A: The drop in the cross-section of the conductor should not exceed 1V.

**Q: How the Master card mode is turned on?**

A: By Andromeda Tool software or Andromeda Pro software.

**Q: How do I know when it is in "Adding" mode or "Deleting" mode (with Master card)?**

A: By the indication. When 50 Hz flashing frequency (fast flashing) is in action, "Adding" mode is in effect; when 2.5 Hz flashing frequency (slow flashing) is in action, "Deleting" mode is in effect. Total extinction of flashing means that every single card is being deleted. This corresponds to the number of presentation of the Master card: 1 – adding; 2 – deleting; 4 – total erasure. After the comprehension of the mode, the indication lights up permanently for the time for which it waits for card. Then it shuts and exits of mode.

**Q: How do I change the outputs' mode of work from NO to NC?**

A: Through any of the softwares. Enter in Setup (on the controller) and tick the box "Output masks". The number before the box corresponds to the number of the output.

## Software



INSTRUCTIONS  
USE OF

ANDROMEDA TOOL  
<http://goo.gl/r88288>



INSTRUCTIONS  
USE OF

ANDROMEDA PRO  
<https://goo.gl/cSuFFa>



DISCUSSIONS AND  
INFORMATION

<https://goo.gl/zbshx1>

DOWNLOAD ANDROMEDA TOOL

<http://www.securitybulgaria.com/files/Andromeda/NewAndromedaToolLast.zip>

REMOTE SUPPORT

<http://www.securitybulgaria.com/files/Andromeda/PolimexSupport.exe>

## Web SDK

## Working with Master cards

**Adding card(s)**

Approach the Master card to the reader once. The indicating light-emitting diode should flash in fast tact. Do wait for it to stop flashing and to keep permanent light (this means the controller is currently in a state/mode of adding cards). Do approach the cards you want to add consecutively. After you finish with the adding, you shall have to wait for the light-emitting diode to shut down. When it does, the cards are added.

**Deleting card(s)**

Approach the Master card to the reader twice. The indicating diode should flash in slow tact. Do wait for it to stop flashing and to keep permanent light (this means the controller is currently in a state/mode of deleting cards). Do approach the cards you want to delete consecutively. After you finish with the deleting, you shall have to wait for the light-emitting diode to shut down. When it does, the cards are deleted.

**Erasure of all cards**

Approach the Master card to the reader four times. After the diode shuts down – all cards shall be deleted.

